

ACCUSTAT™ STATIONARY & ACCUSTAT™ BMS

Differential Pressure Monitors

Installation and Operation Manual

Read and Save these Instructions

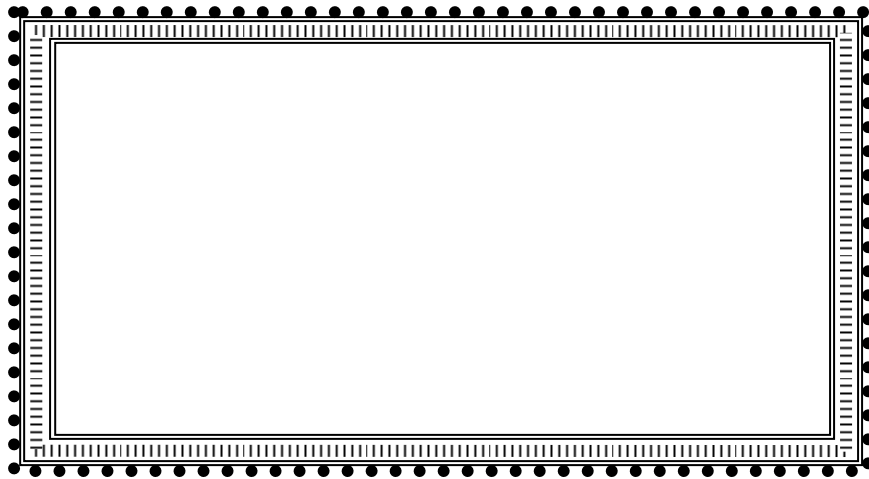

Manufactured by

BIOLOGICAL
Controls

749 Hope Road, Suite A- Eatontown, NJ 07724 USA
Tel: 800-224-9768, 732-389-8922 Fax: 732-389-8821
www.biologicalcontrols.com

SAFETY INSTRUCTIONS

Read and Save these Instructions

Understanding the signal words: **DANGER**, **WARNING** and **CAUTION**.

These words are universally used for overall safety:

⚠ DANGER Signifies the most serious hazards, which will result in severe personal injury or death.

⚠ WARNING Signifies hazards, which could result in personal injury or death.

⚠ CAUTION Signifies unsafe practices, which would result in minor personal injury or product and property damage.

⚠ WARNING **READ INSTRUCTION MANUAL THOROUGHLY AND FOLLOW ALL DANGER, WARNING OR CAUTION NOTES AND LABELS ATTACHED TO THE UNIT BEFORE STARTING INSTALLATION OR MAINTENANCE ACTIVITIES. IMPROPER INSTALLATION, ADJUSTMENT, ALTERATION, SERVICE, MAINTENANCE, OR USE CAN CAUSE FIRE, ELECTRICAL SHOCK, OR OTHER CONDITIONS THAT MAY CAUSE PERSONAL INJURY OR PROPERTY DAMAGE. WEAR SAFETY GLASSES AND WORK GLOVES AND FOLLOW ALL SAFETY LOCAL BUILDING AND ELECTRICAL CODES. CONSULT A QUALIFIED INSTALLER, SERVICE AGENCY OR YOUR SUPPLIER FOR INFORMATION OR ASSISTANCE.**

Table of Contents

<u>Section:</u>	<u>Page#</u>
1. INTRODUCTION.....	1
1.1. Remote Monitoring.....	1
2. Keyed Switches.....	1
2.1. Power.....	1
2.2. Positive/Negative Pressure Mode.....	1
3. OPERATION and SET-UP.....	2
3.1. Quick-Reference Instruction Guide	2
3.1.1. Power.....	2
3.1.2. Display Activity:.....	2
3.1.3. Display (Units).....	2
3.2. PRESSURE ALERT FUNCTION.....	2
3.2.1. Alert Mode Switch	2
3.2.2. Alert Set-Point Adjustment.....	2
3.2.3. Hospital Configuration Example:.....	3
3.3. “ZERO” Display Adjustment	3
3.4. Typical Pressure Alert Set-Up Examples:	4
3.4.1. Negative-Pressure	4
3.4.2. Positive-Pressure	4
3.5. Audible Mute.....	4
3.6. Alarm Contacts for Remote Options.....	5
4. INSTALLATION.....	5
4.1. ACCUSTAT™/ BMS Mounting	5
4.2. Remote Panel Mounting	5
4.3. Sample Tube Wall Mount Kit.....	5
5. MAINTENANCE INFORMATION	6
5.1. General.....	6
5.2. Cleaning	6
6. WARRANTY.....	6
6.1. Making a Warranty Claim.....	6
7. SPECIFICATIONS.....	7
8. APPENDIX A	8
8.1. Printed Wiring Boards	8
8.1.1. EDI 091009 REV Model	8
8.1.2. ACCUSTAT™ Earlier Model (REV J 2008)	8
8.1.3. ACCUSTAT™ Earlier Model (REV 2002).....	9
8.1.4. Building Management System Option (BMS)	9
8.2. Enclosure Dimensions.....	10
8.3. Schematics	11
8.3.1. Building Management System Option (BMS)	11
8.3.2. Remote Panel.....	12
9. CALIBRATION PROCEDURE.....	13
9.1. W.C. (H ₂ O) Calibration	13
9.2. Pascal (Pa) Calibration Procedure	14
10. Troubleshooting	15
11. Wall Mounting Template	16

ACCUSTAT™ STATIONARY and ACCUSTAT™ BMS **Differential Pressure Monitors**

⚠ WARNING

Sampling Medium:

Air or non-corrosive, non-explosive gas only

Do Not Exceed Overload Pressure: $\pm 138''$ WC (H²O) or ± 34 K Pa Maximum

1. INTRODUCTION

The ACCUSTAT™ Stationary model is designed specifically to monitor the air-pressure conditions within an enclosed room relative to the surrounding environment. Controlling and monitoring pressurization is a vital step in the creation of a compliant, controlled, and safe environment within medical facilities and other critical areas. Since both pressure ports are accessible the unit may be mounted in one area and tubing can be run to the areas of interest to the ACCUSTAT™.

The ACCUSTAT™ (BMS) Unit is designed to connect to a Building Management System. The BMS unit provides the additional computer interface circuitry required by a Central Computer and Control System to monitor and react appropriately to pressure changes within a facility. See the Specifications Section and Appendix for a listing of features, functions and schematics.

1.1. Remote Monitoring

The Remote Panel option is available to monitor the Alarm Status of up to six (6) ACCUSTAT™ units from a central area (such as a nurse station). The wall mounted unit is the same size as the ACCUSTAT™ and is equipped with per-room Status LEDs and mutable buzzer. See the Appendix for schematics and installation information.

2. Keyed Switches

The key-switch is located on the top surface of the unit and may be removed in either select-position to prevent unauthorized use. All ACCUSTAT™ Key-Switches use the same key within a model-vintage.

2.1. Power

The Power on/off Key Switch is standard on stationary units (BMS units have no switch since power is controlled by the central computer).

2.2. Positive/Negative Pressure Mode

This factory option switch is utilized in applications where the ACCUSTAT™ is anticipated to make frequent changes in the two pressure monitoring modes.

The switch allows the user to change the pressure monitoring mode of the device without having to open the unit to either move the internal selection jumper (JP1) or change the air sample tube on the pressure ports.

3. OPERATION and SET-UP

3.1. Quick-Reference Instruction Guide

3.1.1. Power

The ACCUSTAT™ is powered with twelve volts (12VDC) for the standard unit and twenty-four volts (24VDC) required for the Building Management System (BMS) option. A universal-input power-module is provided with each ACCUSTAT™ to convert 90-250VAC @50/60 Hz wall-plug power to the 12 VDC required by the ACCUSTAT™. The power-module is equipped with a US-domestic AC wall-plug (international customers receive an adaptor-kit). A 12VDC modular-connector is supplied on the power-module cable to connect to the associated ACCUSTAT™ input plug.

The BMS unit is powered from the facility Building Management System circuits that provide a 24VDC source. A euro-type screw connector is provided on the BMS unit to interface both the power and loop-monitoring cable-wires.

Note: If for any reason an ACCUSTAT™ BMS unit is removed from the central 24VDC power source, a separate 24VDC power-module will be required to power the BMS unit to make it function as a standard stand-alone ACCUSTAT™.

3.1.2. Display Activity:

It is NORMAL for the display to fluctuate periodically. The air-pressure in most buildings can be dynamic at times. Even slight pressure changes are detectable by the ACCUSTAT™. Fluctuations are likely due to activity in the hallways caused by the opening and closing of stairway, room, or fire doors. Elevator operation and air-conditioning systems can also cause pressure fluctuations.

The display will be updated constantly with the room pressure readings approximately once a second. Positive pressures are displayed with no sign. Negative pressures are displayed with a negative sign (-).

3.1.3. Display (Units)

The ACCUSTAT™ can display pressure-units in either PASCAL's (Pa) or Water Column (H²O, WC). Place the Units-Selector jumper on the rear of the circuit board in the proper position for the intended application. See the Appendix section to locate the jumper and the correct position.

3.2. PRESSURE ALERT FUNCTION

A visual or audible alert feature is available to indicate when pressure-levels are attained or exceeded (without the need to look at the LCD display).

3.2.1. Alert Mode Switch

This three-position switch when in the left-most "Set" position causes the LCD Display to switch from showing the differential pressure across the pressure-ports ("P1" and "P2") to displaying the desired Alert Set-Point. The center switch-position will mute the Alert buzzer if active and the right-most position allows the buzzer to sound on any red alert level after a one minute-delay. The switch **must be returned to the center** (normal) position after adjusting the Alert Set-Point to allow the LCD to display the differential pressure.

3.2.2. Alert Set-Point Adjustment

Slide the “Mode” switch to the “Set” position. The LCD Display will now show the Set-Point pressure-level that establishes either a “Green” or “Red” LED alert depending on which pressure-port is used for the sampling and the location of the ACCUSTAT™ relative to the area being sampled. Use a small jeweler’s screwdriver to change the pressure set-point potentiometer through the “Adj” access hole in the front panel. After setting the Alert pressure-level, Always return the Mode Switch to either the “Mute” or “Aud” position so the LCD display can return to the normal mode of showing the differential pressure between the ACCUSTAT™ location and the area that is connected to the sampling tube.

3.2.3. **Hospital Configuration Example:**

A sampling-tube is attached to the ACCUSTAT™ “P2” pressure-port and the “P1” port is left open. The Pressure Alert set-point is adjusted to -.012” WC. The ACCUSTAT™ is installed in the hallway outside the room to be monitored. The “P2” sampling tube is routed thru a ¼ inch hole thru the wall into a patient room. A wall-plate kit is included with each ACCUSTAT™ to cleanly terminate the sampling tube on the patient-room wall.

In this configuration, when pressures in the patient-room are more positive than the alert set-point the Alert LED will start to flash red and conversely more negative pressures will cause the LED to glow green. If the Alert LED remains flashing red for one minute or more an internal buzzer will sound and relay contacts will close to signal remote-station circuits of the situation. If the sampling tube port “P2” is used instead of “P1”, then pressures more negative than zero will cause the Alert LED to flash red and positive pressures will cause the LED to turn green.

When the patient-room is used for an isolation function the air-pressure in the room should generally be negative relative to the hallway such that contaminated patient-room air does not flow into the hallways. For operating rooms just the opposite is desired to prevent contaminated air from entering the surgery area. Since “more-negative” or “more-positive” terms are relative to what pressure-port (P1 or P2) is used for pressure sampling, always consult the facility engineer to determine what room-pressure alerts need to be set and monitored for a particular application.

An optional POS-NEG key-switch is available to easily change the meter to function as either a positive or negative pressure monitor without having to move the sampling tube ports. If the external switch is not equipped a “jumper” on the inside of the unit can be used to change the pressure monitoring mode. See the Appendix for correct jumper settings.

3.3. **“ZERO” Display Adjustment**

The ACCUSTAT™ display may need to be adjusted to “zero” after an installation. The unit is calibrated at the factory to display .000”W.C. or 0.00 Pa for differential pressure monitoring when both the P1 and P2 monitoring ports are at the same pressure. Each unit is also calibrated at ±.250”WC and ±6.25 Pa. See the Calibration section of the Appendix for factory calibration methods and other information.

Allow the unit to be powered and reach room temperature before making adjustments.

Example: W.C. (H²O) ZERO adjustment.

- Power the ACCUSTAT™.
- Allow 5-15 minutes warm-up to stabilize the circuits.
- Set the Pressure Alert Mode Slide Switch to the “Mute” or “Aud” position (normal). The “set” position is used **only** to display or set the desired Alert Pressure Level. *Always*

return this switch to either the Mute or Aud position for normal pressure monitoring.
The following “zero” display calibration cannot be performed if the Alert Mode switch is in the “set” position.

- For the highest accuracy, loop the tubing from transducer Port “P1” to “P2” to prevent outside interference during the Zero adjustment. If the unit is already mounted on a wall, a long piece of tubing may be attached to the room sampling tube hole and extended temporarily to be next to the ACCUSTAT™. If this is not possible, make sure that the door is opened between the ACCUSTAT™ location and the monitored area during the procedure.
- Turn the “Zero” adjustment potentiometer located below the LCD Display using a jewelers screwdriver. Adjust until the display reads -.000 and then very slowly continue until the minus (-) sign just disappears (.000). **Never force the potentiometer past the left or right stops.** See the Appendix Calibration section for instructions on adjusting an internal coarse adjustment pot if the fine adjustment is out of range.

3.4. **Typical Pressure Alert Set-Up Examples:**

3.4.1. **Negative-Pressure**

Isolation Room Example: The ACCUSTAT™ is mounted on the wall in the hallway outside an Isolation Room and a sampling tube from the ACCUSTAT™ (-) port is connected to the pressure port labeled “P2”. The tube runs through the wall into the Isolation Room where it is terminated on a stainless-steel wall plate mounted on the wall of the Isolation Room. (A wall-plate kit is included with each ACCUSTAT™). The ACCUSTAT™ pressure (+) port labeled “P1” is not used (this port senses the hallway pressure).

In this example, the Isolation Room is checked for a negative-pressure of at least -0.012WC relative to the hallway pressure. To be alerted to the fact that the pressure is at or below this level (more negative) without having to look at the LCD display set the Alert Select switch to the right-most position. In this mode the Pressure Alert LED will start flashing red and after a one-minute delay the audible alarm will sound when the room pressure goes positive relative to the set-point. If the sampled pressure is -0.012WC or more negative; the LED will remain green.

3.4.2. **Positive-Pressure**

Operating Room Example: In a hospital the operating rooms are checked from the hallway with the same sampling tube set-up described above to detect positive-pressures at or above the set-point of +0.012”WC.

The user adjusts the ACCUSTAT™ Alert Set-Point to (positive) +0.012WC.

Under these circumstances the Alert LED is Green when the sampled pressure is at or more-positive than the set-point. When the pressure is more-negative than the set-point the Alert LED will flash red (and ultimately set off the audible alarm after 1 minute).

3.5. **Audible Mute**

The Pressure Alert Mode Switch can be moved to the Mute position to turn-off the audible sound without affecting the LED or remote monitoring functions.

3.6. Alarm Contacts for Remote Options

The remote relay contacts are available on connector P3. Reading from left-to-right, Pin 2 is NO (normally open). Pin 3 is NC (normally closed) and Pin 4 is the C (common) pin. Jumper JP2 will reverse the “normal” action of the contacts to provide a fail-safe mode that may be required for certain applications. The other relay contacts on P3 and Jumper JP3 are reserved for custom blower-control options.

4. INSTALLATION

4.1. ACCUSTAT™/ BMS Mounting

Mount the ACCUSTAT™ such that the pressure sampling-tubing leaving the transducer can line-up (in straight-line) with the sampling tubing wall kit in the adjacent room. If the sample tube is run through an anteroom, over a ceiling or another non-direct method; the tubing must be routed such that there will be no kinks, sharp bends or debris forced inside the tubing. Use silicone calk around the hole that enters the monitored-room to prevent air-leaks.

Use a level to scribe a 7” inch line on the wall where the unit will be mounted to represent the bottom horizontal edge of the chassis. Remove the four (4) Philips-head screws that hold the two stainless-steel chassis parts together. Separate the wall anchor-plate (rear-cover). Align the bottom-edge of the rear cover chassis with the 7 inch line and trace-out the L-Shaped cut-out and the three (3) anchor screw positions onto the wall. (A Wall Anchor-Plate Template found in the Appendix may be cut out and taped to the wall for the same purpose.)

Use a ¼” drill-bit to drill the center-positions of the three mounting screws when utilizing the plastic anchors and screws supplied with the unit. Otherwise, select the proper drill-bit for customer-selected mounting hardware. The wiring and pressure tubing should be routed within the L-shaped cut-out area. Provide enough slack in the wiring to enable the unit to be removed from the wall to access and view the rear of the circuit board if needed.

A small slot is provided in the top cover of the unit for low voltage wiring that may be sent from a power module mounted in a ceiling outlet and preferably routed through surface mounted conduit.

4.2. Remote Panel Mounting

Use the same mounting procedures as the ACCUSTAT™ .

4.3. Sample Tube Wall Mount Kit

Drill a hole for the sampling tubing using the ¼” drill bit. Push the sampling tube onto the ACCUSTAT™ pressure transducer port (usually P2) and then through the wall. To install the sampling-tube wall mount kit in the room, pull the tubing through the grommet so the wall-plate is flush with the wall. Mark the centers of the two mounting holes on the wall and drill a 7/32” hole for each of the two plastic wall anchors found in the kit. Tap the plastic anchors into the holes with a small hammer. Mount the wall-plate using the screws in the kit.

5. MAINTENANCE INFORMATION

CAUTION

Remove power from the unit during all maintenance routines.

5.1. General

The ACCUSTAT™ requires no maintenance other than cleaning surfaces that may become dirty during normal use.

5.2. Cleaning

Keep water away from the unit and wall plug power module. If the unit comes into contact with water remove power from the unit until all of the liquid has evaporated. Take care not to scratch the bezel lens covering the LCD display. Treat the bezel like a camera-lens or eye glasses by avoiding both harsh cleaners and tools that may scratch the surface.

Never use spray applicators to apply solvents. Use a soft damp (not wet) cloth to wipe the surfaces of the unit as required. The cloth may be soaked in a mild dish detergent or denatured alcohol and wrung-out thoroughly to assure that no running liquid will drip into the ACCUSTAT™.

6. WARRANTY

Limited Warranty:

Biological Controls warrants that the ACCUSTAT™ to be free of defects in workmanship and materials during normal use and service for a period of Twelve (12) months from the date of purchase by the original end user.

If at any time during the warranty period the product is defective or malfunctions, Biological Controls or its dealer or distributor, from whom the product was purchased, shall at the option of Biological Controls replace or repair the defective part or component.

This warranty shall not apply if it is shown that the defect or malfunction was caused by damage due to shipment, improper electrical connections, or improper use or abuse of the product.

The sole responsibility of Biological Controls shall be to repair or replace the product within the terms stated above. Biological Controls shall not be liable for any loss or damage of any kind, including any incidental or consequential damages resulting, directly or indirectly, from any breach of warranty, expressed or implied, or any other failure of this product. (Some areas do not allow the exclusion or limitation of incidental or consequential damages, so this limitation may not apply to you.) The warranties set forth are exclusive and Biological Controls expressly disclaims all other warranties, whether written or oral, implied or statutory, including but not limited to any warranties of merchantability, workmanship, or fitness for a particular use.

In our continuing effort to produce the highest quality products, we reserve the right to change or alter product specifications and materials without notice.

This warranty gives you specific legal rights and you may have other rights, which vary, from state to state or country to country.

6.1. Making a Warranty Claim

To make a warranty claim or if you have questions about the warranty policy, contact the distributor from whom you purchased the product.

NOTE: Do not return any products or components directly to the factory without a factory issued "Return Merchandise Authorization (RMA) number" issued by the Biological Controls Customer Service Department.

Any products returned without the issuance of the RMA number will be refused and returned to shipper.

For questions related to this warranty call or write:

Manufacturer:	
BIOLOGICAL CONTROLS	TEL: 800-224-9768
749 Hope Road Suite A	FAX: 732-389-8821
Eatontown, NJ 07724	WEBSITE: www.biologicalcontrols.com

7. SPECIFICATIONS



ACCUSTAT™ Specifications

ELECTRICAL

- Voltage typical: 12V Min. / 15V Max.
(International 12VDC Power Module)
Typical Current: 100 mA max
Maximum Power: <1.5W
- BMS option: Voltage 24VDC±10%
Typical Current: 120mA max
(Power supplied by Bld. Mngmt. System)
Power: <2W
- On/Off Key Switch (not on BMS)

TRANSDUCER

- Low Pressure Differential Vacuum Gauge/Amplified
- Medium: Air or Non-Corrosive, Non-Explosive Gas
- Application Pressure Range: -0.100 to +0.100" H²O
- Overload Pressure: ±138" WC or ±34K Pa Maximum
- Accuracy of Reading: ± 1% F.S.

MECHANICAL DATA

- Wall Mount Enclosure: Stainless Steel #4 Polish
- LCD Display: ½ inch High Single Line
- Dimensions: 7.367" (W) x 3.25" (H) x 2.25" (D)
- Weight: 22 oz. (BMS option 24 oz.)
- Operating Temperature: 55 - 105°F (13°C to 41°C)
- Sampling Tube: Requires a 1/4 Inch Hole into the Sampling Area. A Stainless Probe Plate kit w/ 1' of ¼" tubing included.
- Operating Humidity: 10% to 94% RH Non-condensing Operating

OPERATIONAL FEATURES

- LCD Display Refresh Rate: 1.0 Second
- Visual Alert LED: Green / Red Alert Modes
- Alert Set Point Storage: Non-Volatile Memory
- Alert Set Point: User Defined; Front Panel Adjusted
- Set Point Alerts (Flashing/Steady Modes)
- Audible Alarm: One Minute Delayed Buzzer
- Zero Calibration: Front Panel Adjusted
- Accuracy of Alarm Output: ± 1% of Set Point
- Standard Application Range: ± 0.1" H²O (± 25 Pa)
- Resolution: 0.001" H²O (0.1 Pascal's)
- Remote Monitor Outputs:
- SPDT Relay Contacts 1A max, Resistive, @30VDC or 120 VAC
- Tamperproof Controls: On/Off Key Switch
- Pos/Neg Key Switch (optional)
- Wall Mounting Hardware Kit
- Selectable Pos/Neg Pressure Modes
- Both Pressure Ports Accessible for Probe tubing

Remote Monitor Outputs:

- SPDT Relay Contacts - 1A max (Resistive) @ 30 VDC or 120 VAC

Building Maintenance System Option (BMS):

- 4-20ma Current Loop Output
- 0-5VDC, 2.5V at Zero Pressure 2mA max
- 0-10VDC, 5V at Zero Pressure 2mA max
- Max Loop Resistance is 580 OHMS

8. APPENDIX A

8.1. Printed Wiring Boards

8.1.1. EDI 091009 REV Model

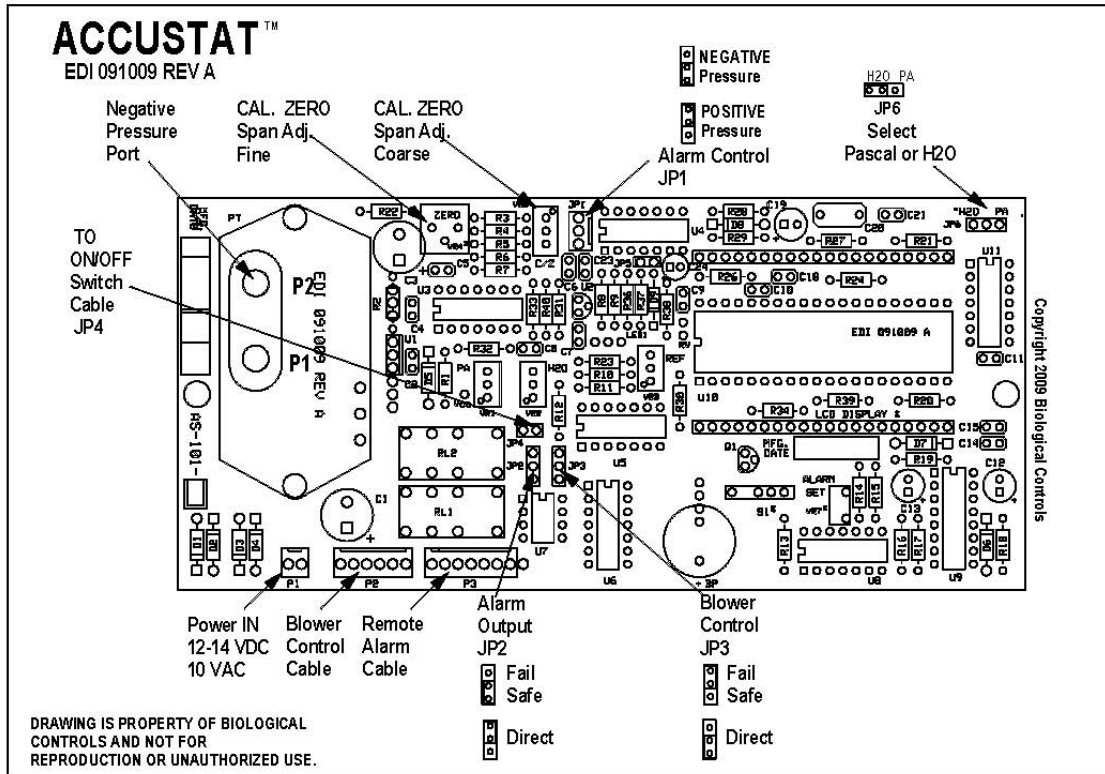

8.1.2. ACCUSTAT™ Earlier Model (REV J 2008)

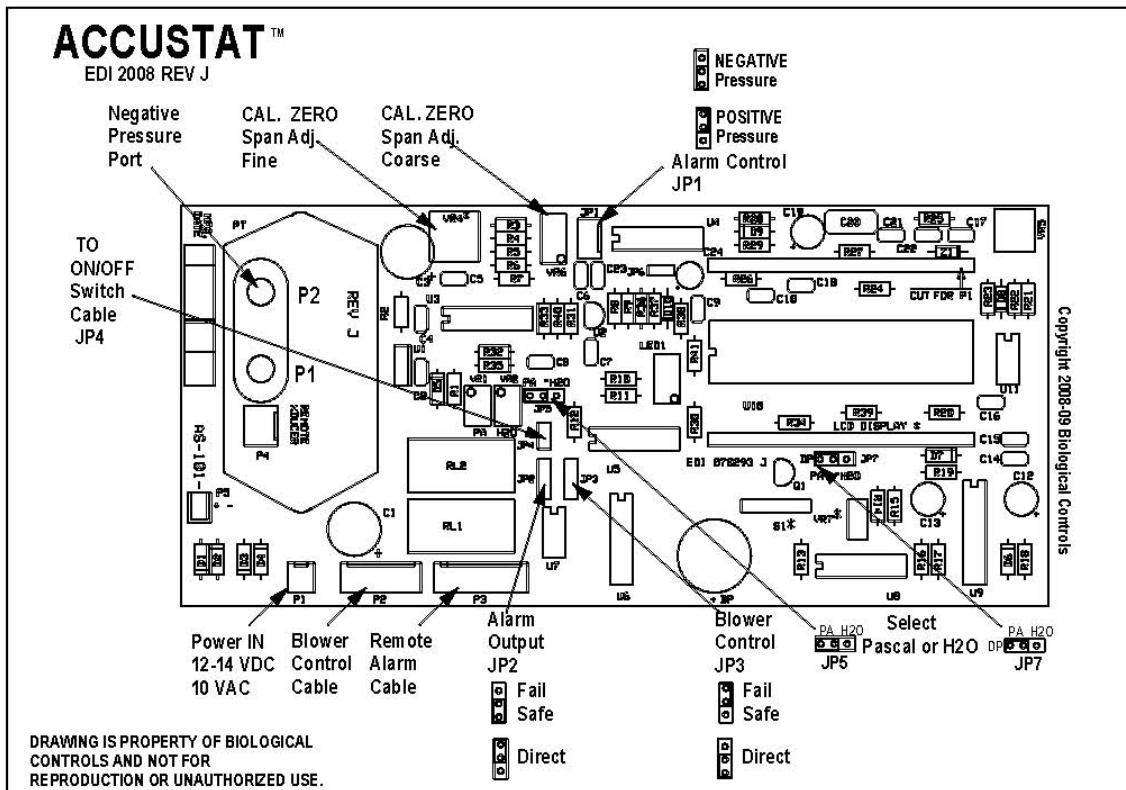

8.2. Enclosure Dimensions

ACCUSTAT™ and Remote Panel Front Covers. The Wall Mounting Plate is the same for both. Dimension units are in inches.

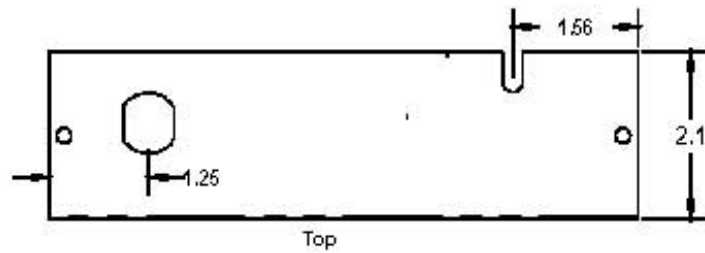

Accustat Dimensions

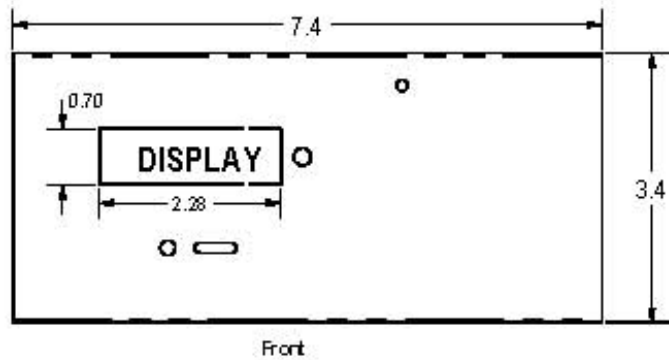

304 #4 Stainless Steel
Chassis for all Units
7/1/2010

Remote Panel Dimensions

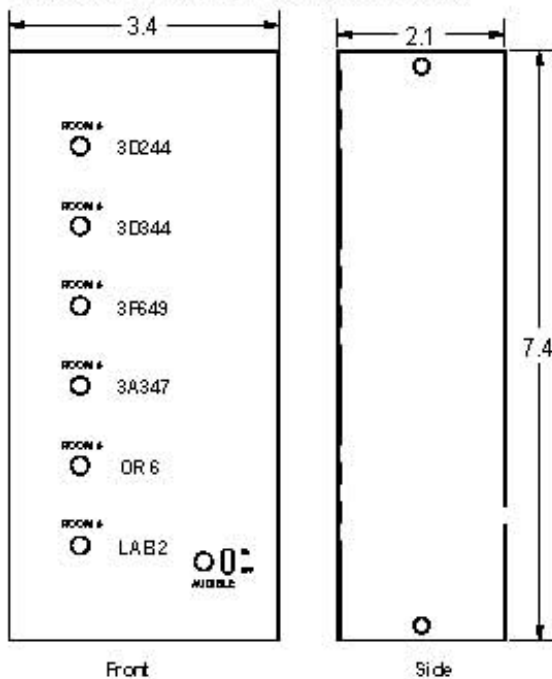

Wall Mounting Plate Dimensions

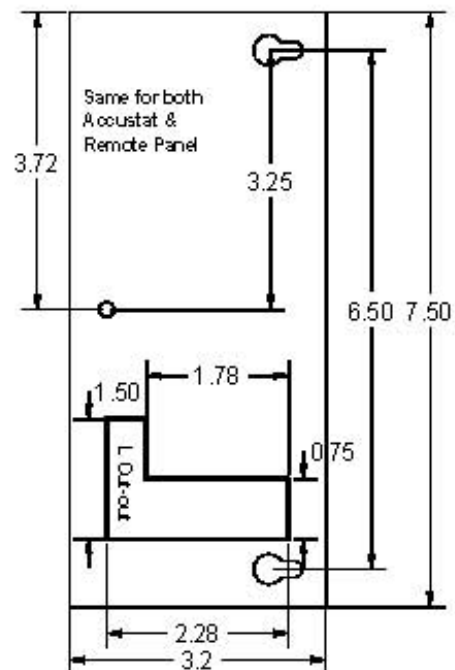

8.3. Schematics

8.3.1. Building Management System Option (BMS)

Internal BMS Circuit Board

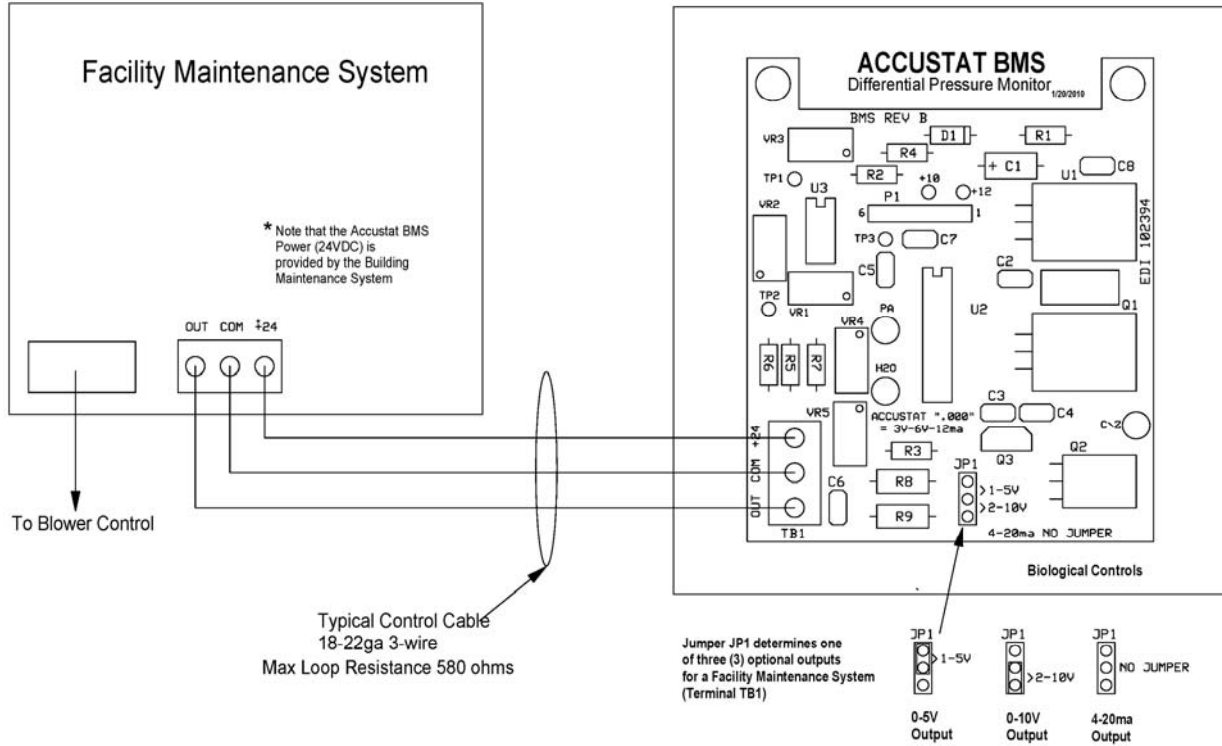

9. CALIBRATION PROCEDURE

Follow standard electrostatic discharge (ESD) practices and procedures (i.e.; use a properly grounded wrist-strap) during calibration or maintenance activities to avoid static-electricity discharge currents that can damage the unit.

Note: The Pressure Alert Mode-Switch must be in the “Mute” or “Audible” position to calibrate the differential pressure zero setting.

If the unit cannot be adjusted per the instructions, contact the factory technical support for advice before possibly having to return the unit for calibration. Always obtain an RMA number from the factory before returning the unit.

When possible calibrate the ACCUSTAT™ after installation so variables due to the mounting position and environmental conditions within the application-area are eliminated.

When calibration is performed on a bench, place the unit flat on the table (in a horizontal position) so that the LCD display is positioned in the upper left hand corner, the on/off key-switch is on top of the unit, the black three (3) position slide switch is under the display in the center (alarm-mute) position.

9.1. W.C. (H²O) Calibration

1. Connect the DC power module supplied with the unit or a 12-14VDC power source to the two (2) pin power connector shown on the schematic. The connector is located on the back of the circuit board in the lower left hand corner. See the Appendix for schematic diagram. BMS units require a 24VDC power source.
2. Place jumper JP6 on the rear of the circuit board in the correct position for the unit to display WC (H²O) or Pa pressure-units. (See Appendix diagrams for location information).
3. Place jumper JP1 on the rear of the circuit board in the correct position for the unit to be in the negative (-) pressure-mode. If a pressure select key-switch is equipped there is no need to locate JP1. Set the switch to the negative (-) pressure-mode position.
4. Using the power key-switch, turn the ACCUSTAT™ “on” for at least 15 minutes to allow for temperature stabilization. Check the voltage at the input connector pins with a DC voltmeter (under load) to verify the correct voltage. The internal voltage-regulator will easily compensate for ±10-20% input voltage tolerances. *Note: Since the power source for BMS units is controlled by the facility maintenance system, an “on”-“off” switch does not normally exist on BMS units. Use an external 24VDC, 200ma power source for calibration.*
5. Adjust the unit to display .000”W.C. or 0.00 Pa for differential pressure monitoring when both P1 and P2 ports are at the same pressure. Each unit is also calibrated at the higher levels of ±.250”WC and ±6.25 Pa by applying these pressure-levels to transducer-port “P2” while “P1” remains open.
 - Open P1 and P2 ports or tie them together with a short piece of tubing to assure that both are at the same pressure and that local air-currents do not affect the procedure. Check the display for the zero reading.
 - Turn the zero adjustment screw with a flat-head jeweler’s screwdriver to obtain a display reading of .000. The screw is accessed through a small hole to the right of the LCD display. If the display

is reading a negative (-) value rotate the screw clockwise. If a positive (+) value is displayed then rotate counter-clockwise. Do not force the screw in either direction.

If the “Zero” (Fine- Adjustment) is out of range a Coarse-Adjustment (pwb marking C/Z) on the inside of the unit can be altered. Adjust the “Zero” (fine adjustment) on the front panel such that it is centered (screw-slot running up and down in the vertical direction).

To perform this procedure the ACCUSTAT™ cover is removed by unscrewing the four (4) screws attaching the front cover to the wall plate. Then two screws that mount the printed wiring board must be removed to gain access to the rear of the ACCUSTAT™ circuit board (pwb).

See the proper circuit diagram in the Appendix and locate the Coarse-Adjustment potentiometer accessible after the cover and circuit board are removed. A hole in the BMS pwb (marked C/Z) is used to access the potentiometer screw.

Carefully turn the adjustment screw left or right to get the meter to read close to .000. The adjustment does not have to be exact since the final zero setting will be done with the fine adjustment on the front after the cover is replaced.

6. Apply -.250” W.C. pressure from a calibrated source to the P2 port (upper port) located on the black pressure-transducer. If -.250” W.C. does not display on the LCD then adjust VR1 (trimmer pot) located near the white AXICOM relays. Set the VR1 so that -.250” W.C. is displayed on LCD. When the BMS pwb is present and covers the pot, adjustment is made through the pwb hole marked “H²O” just above the pot.
7. Remove pressure from ACCUSTAT™ P2 transducer port and the display should read .000.
8. Repeat the last 2 steps of the procedure to verify repeatability.

9.2. Pascal (Pa) Calibration Procedure

1. Follow steps 1 thru 5 from the WC Calibration procedure above. Make sure the JP6 is in the Pa position.
2. Apply -62.5 Pa. from a calibrated pressure source to the P2 port (upper port) located on the black pressure transducer. If -62.5 Pa. does not display on the LCD then adjust VR2 (trimmer pot) located near the white AXICOM relays. Set VR2 so that -62.5 Pa is displayed on LCD. When the BMS pwb is present the adjustment is made through the pwb hole marked “Pa” just above the pot.
3. Remove pressure from ACCUSTAT™ and 0.00 should now be displayed.
4. Repeat the last 2 steps of the procedure to verify repeatability.
5. Calibration procedure is complete.

10. Troubleshooting

<u>Problem</u>	<u>Solutions</u>
No Display	Check Power Voltage and Connections
Display remains neutral	Is room completely sealed, is exhaust greater than supply (check with velometer)? The 3-position slide switch must be in the center or to the right.
Display does not move during Alert set point adjustments	The 3-position slide switch must be set to the rightmost position. (return to center or left after adj.
Alert LED remains Green for alarm condition	Check Alert set-point. Check slide switch for proper position. Is sampling tube on proper transducer Port?
Erratic Display, will not stabilize when setting “Zero”	Sampling tube must be disconnected or extended to be next to the ACCUSTAT™. Check power connections and voltage stability.
Erratic Display when sampling tube is connected	Check for proper connection of the sampling tube to the ACCUSTAT™ and the wall mount fixture. Inspect tubing for bends, cracks, pinching or obstructed. Check power connections and voltage stability.
Audio Alarm (buzzer) does not sound when set-point is reached and the LED is flashing red.	Check the 3-position slide switch to make sure it is not in the “Mute” position. Allow 1 minute delay between an alarm condition and the sound. Every time the alarm condition disappears the minute delay is reset and starts counting again.

11. Wall Mounting Template

The same template is used for both the ACCUSTAT™ and the REMOTE PANEL

**Accustat & Remote Panel
Wall Anchor Plate Template**

Front-View (facing the unit after it is installed)

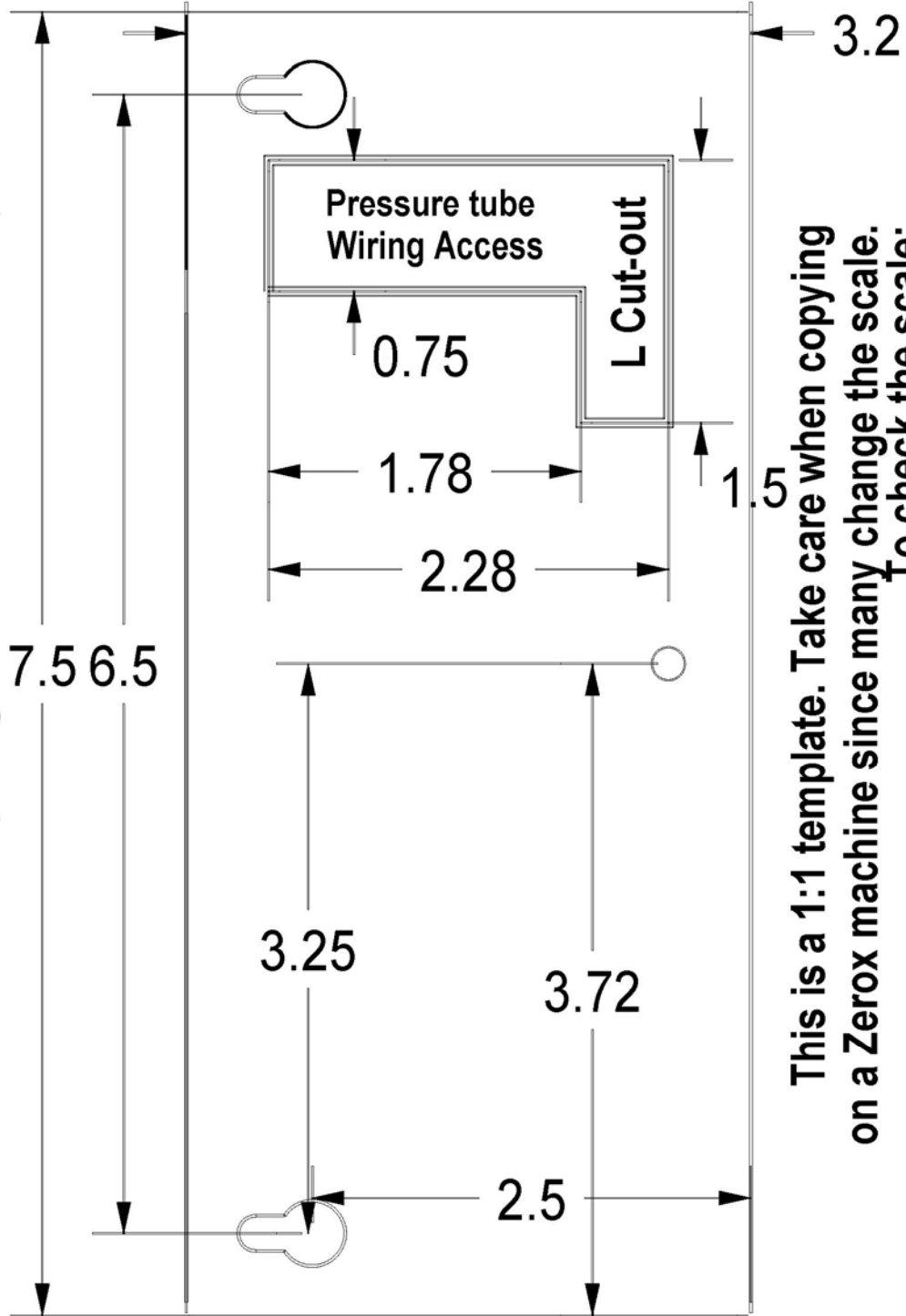

This is a 1:1 template. Take care when copying on a Zerox machine since many change the scale. To check the scale:

This line should measure exactly 1 inch _____ 7/29/2010