

BIOLOGICAL
Controls

SUBMITTAL DRAWING

MICROCON WallMAP WM-002

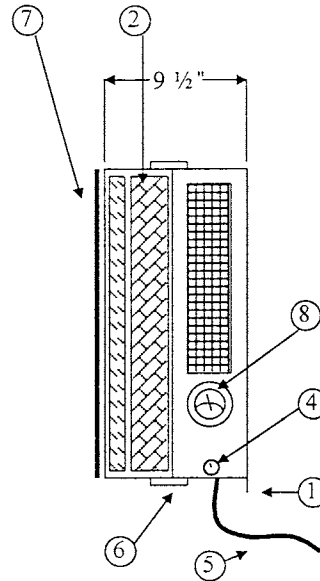
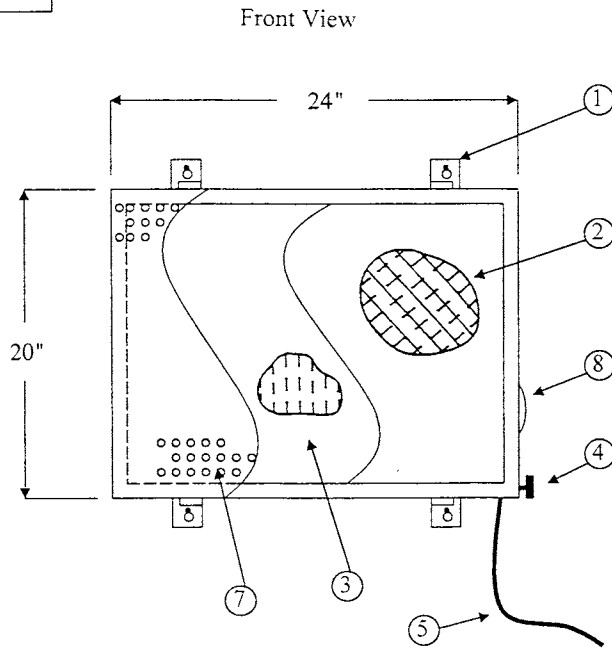

- (1) STAINLESS STEEL MOUNTING ANGLE BRACKETS WITH KEY HOLE SLOT TOP AND BOTTOM
- (2) 1 EA. 20" X 24" X 3" PLASTIC LAMINATED PLYWOOD FRAMED HEPA FILTER 99.99% EFFICIENT ON PARTICLES 0.3 MICRON IN SIZE OR LARGER
- (3) 1 EA. 1" TWO PLY POLYESTER SYNTHETIC 35% EFFICIENT PANEL PRE-FILTER
- (4) ELECTRONIC VARIABLE SPEED CONTROL
- (5) 1 EA. 6 FT. 18/3 CORD WITH 115V, 1 PH, 60 Hz HOSPITAL GRADE POWER CORD
- (6) 4 EA. NON-CORROSIVE BLACK VINYL DRAW LATCHES
- (7) 1 EA. 24 GA. PERFORATED STEEL PROTECTIVE SCREEN WITH BLACK MATTE FINISH
- (8) 1 EA. MINIHELIC STATIC PRESSURE GAUGE

NOTES:

- UNIT TO BE CONSTRUCTED OF 20 GA. TYPE 304 STAINLESS STEEL #4 FINISH
- ELECTRICAL REQUIREMENTS: 115V, 1 PH. 60 Hz., 0.7A, 80 W, ELECTRICAL WIRING IS IN ACCORDANCE WITH THE LATEST NEC STANDARDS
- UNIT IS POWERED BY 1 EA. DIRECT DRIVE BACKWARD CURVED IMPELLER MOTOR WITH 150 - 275 CFM DELIVERED CAPACITY, WEIGHT OF UNIT IS 28 #
- 1/4" THK. CHARCOAL GREY 45 PPI EXHAUST FILTER FOAM LINING OF THE BASE SECTION

DRAWN FOR STANDARD	 749 Hope Road Suite A Eatontown, NJ 07724			
	TITLE MICROCON WallMAP Wall Mounted			
DRAWN BY LVB	SIZE	JOB NO.	DWG NO.	REV
APPROVED BY	SCALE	DATE July 19, 2002	SHEET	