

**BIOLOGICAL**  
*Controls*

SUBMITTAL DRAWING

MICROCON ExC-BB MEXCBB-002

**EXC-BB H**

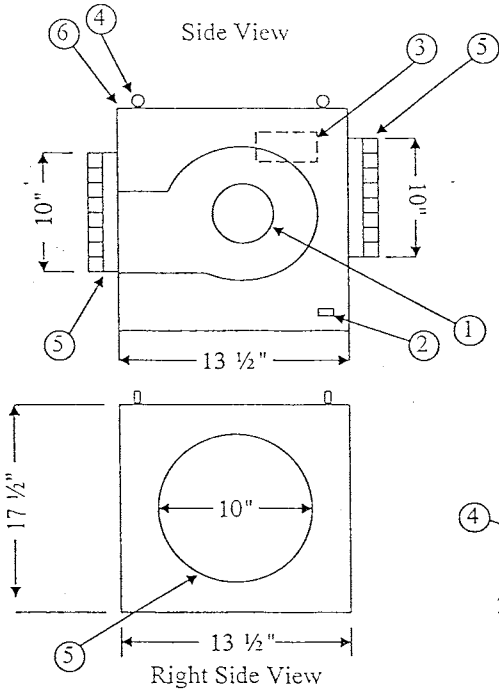

BLOWER BOX

- 1) Blower, Direct Drive Double Inlet, 1/5 HP, 115V-60 Hz.  
8.3 amps, single pole, thermal reset protection, 1075 rpm,  
airflow rating 500 - 835 cfm
- 2) Tie-in cable connection to filter module
- 3) 2 x 4 electrical handy junction box for customer connection,  
with 10 amp fuse
- 4) Eye hook suspension hanger (4 sides)
- 5) 10" dia. X 2" high, steel starter collar
- 6) Unit constructed of 20 ga. baked enamel galvanized steel  
with high density foam soundproofing

Weight 39#

FILTER MODULE

- (1) 10" DIA. X 2" HIGH STEEL STARTER COLLAR
- (2) 1 EA. 22" X 16.5" X 4" ALUMINUM FRAME HEPA  
FILTER 99.99% EFFICIENT ON PARTICLES 0.3  
MICRON IN SIZE OR LARGER
- (3) 1 EA. 1" TWO PLY POLYESTER SYNTHETIC 35%  
EFFICIENT PANEL PRE-FILTER
- (4) 20 GA. HINGED PERFORATED STAINLESS STEEL  
PROTECTIVE SCREEN WITH #3 POLISHED FINISH

- (5) 1 EA. MINIHELIC STATIC PRESSURE GAUGE
  - (6) REAR ACCESS PANEL
  - (7) 4-SPEED ON/OFF POWER SWITCH
  - (8) 4-SUSPENSION HANGERS
  - (9) HOUSING IS CONSTRUCTED OF 16 GA  
ALUMINUM & 16 GA GALVANIZED STEEL
  - (10) TIE-IN CABLE CONNECTION TO BLOWER BOX
- WEIGHT 33 #

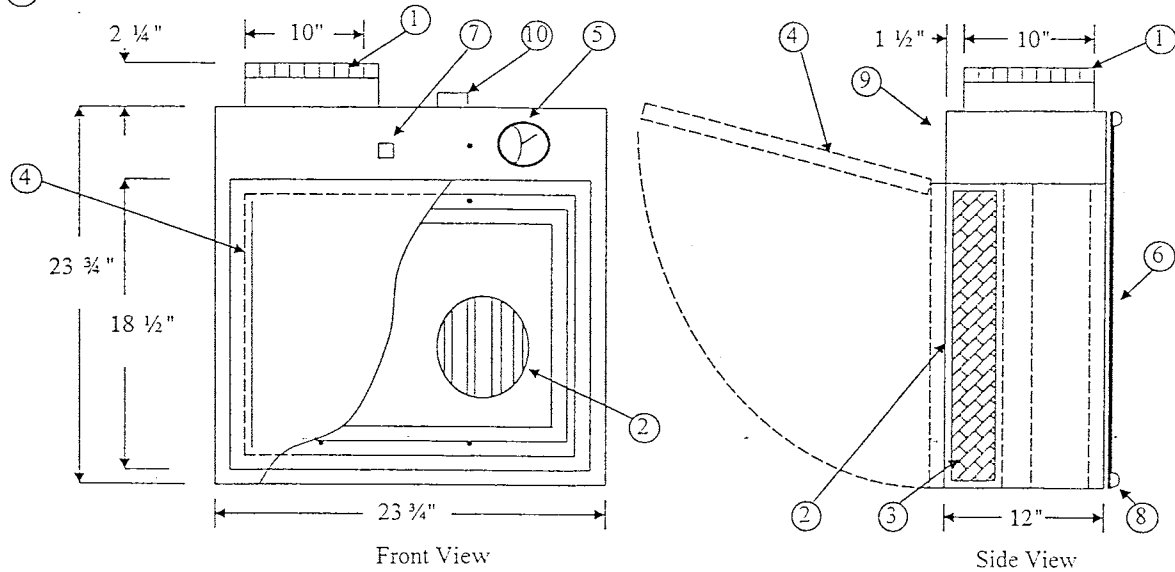

DRAWN FOR		<b>BIOLOGICAL</b> 749 Hope Road <i>Controls</i> Suite A Eatontown, NJ 07724		<b>EXC-BB H</b>	
STANDARD		TITLE <b>MICROCON ExC-BB (Ceiling Mounted)</b>			
DRAWN BY	LVB	SIZE	JOB NO.	DWG NO.	REV
APPROVED BY		SCALE		DATE	SHEET
				July 13, 2002	